



WARRANTY INFORMATION

We sincerely thank you for your purchase and wish you years of pleasure using it!

Tele Vue Warranty Summary

Eyepieces, Barlows, Powermates, & Paracorr have a “Lifetime Limited” warranty, telescopes & accessories are warranted for 5 years. Electronic parts are warranted for 1 year. Warranty is against defects in material or workmanship. No other warranty is expressed or implied. No returns without prior authorization. Please keep your receipts in case you need warranty service.

Lifetime Limited Warranty details online: <http://bit.ly/TVOPTLIFE>

5-Year/1-Year Warranty details online: <http://bit.ly/TVOPTLIMITED>

Subscribe to our Blog for the latest Tele Vue news: <https://bit.ly/TeleVueBlog>

Keep For Your Records

Dealer: _____ City/State/Country: _____

Date (day/month/year): ____ / ____ / ____ Item Code / Description _____

32 Elkay Dr., Chester, New York 10918 (845) 469-4551. televue.com



@televueoptics

(TPM-3015) TELE-POD MOUNT INSTRUCTIONS

INTRODUCTION

Thank you for purchasing the Tele-Pod Mount, a convenient, easy to use, travel mount for your Tele Vue telescope. The Tele-Pod combines the size, weight and flexibility of a photo-tripod with the smooth, balanced altitude/azimuth motions of our yoke and cradle mount head. Tele-Pod is perfect for our lighter weight scopes up to the Tele Vue-76 (up to the Tele Vue-85 for terrestrial uses). The mount can be outfitted with encoders (STN-4001) for Digital Setting Circles / Computers and Eyepiece Caddy Set for maximum viewing pleasure. (See separate instructions).

COMPONENTS

The Tele-Pod (TPM-3015) consists of the mount head (TPH-1016) and tripod (TPT-3017). The head supports the scope and provides vertical and horizontal motions. It features: smooth operating altitude and azimuth bearings with tension adjustments, Delrin scope stop in case the objective end accidentally "nose-dives", and both 3/8"-16 and 1/4"-20 attachment holes on the bottom of the azimuth bearing plate.

The tripod supports the head and allows height adjustment of the scope. The tripod legs have rubber feet. See separate instruction sheet for more features of the tripod. Familiarize yourself with the call-outs on the assembly photos for easy reference and you will quickly learn how to put your Tele-Pod to best use.

SET-UP

WARNING: If setting up on a slope, ensure that the tripod legs are extended so that the head is approximately level with the horizon. Failure to do so could cause the telescope to tip over! This risk increases when using larger, longer scopes.

- 1) Thread the two studs into the two end holes on the bottom of the telescope mount ring. Snug tight using the supplied Allen key.
- 2) Now on the tripod, make sure the Leg Angle Locks are pushed in. Then loosen top leg clamps without completely unscrewing them.
- 3) Extend each leg so that the mount head is slightly above the desired height.
- 4) Tighten leg clamps.
- 5) Spread all three tripod legs to the limit of the Leg Angle Locks and the mount head should be at the desired height and approximately level. If you need the head higher, loosen the center column's height adjustment lock knob and lift to the desired height. Note that the Tele-Pod's vibration dampening is best when the center column is not extended.
- 6) Refer to the Mount Handle instructions to attach it to the mount cradle.
- 7) With the cradle approximately level, set the scope down within it so that the studs pass through the clearance holes.
- 8) Lock the scope down with the supplied knurled knobs.
- 9) Note: Mount head can be moved to other Tele Vue tripods or camera tripods by using the 5/64" Allen to loosen lower set screw on Azimuth bearing plate. Flip over mount and use 3mm Allen to back off 3 small set screws on platform. Normally the bearing plate and platform set screws are tight to prevent unscrewing of mount head as mount is turned in azimuth. Now unscrew the Tele Pod Head.

USE

- 1) Place eyepiece in scope.
- 2) Apply slight and equal tension to altitude bearings using the altitude tension knobs.
- 3) Swing the scope up approximately 45° and check balance. If the scope wants to swing down, slide the scope back until balance is achieved. If the scope wants to swing up, push it forward until balance is achieved. Use mount-ring bat-handle to loosen or tighten scope in ring.
- 4) Apply more tension to achieve the desired feel. Extra tension can be used to overcome a minor out-of-balance condition. However, excessive tension will cause the movement to be "jerky." Severe overtightening could strip the threads in the mount head.
- 5) The basic azimuth tension is set at the factory and should not be readjusted. Should additional azimuth tension be desired, tighten the azimuth tension knob.
- 6) The most stable way of slewing your scope is by grasping a fixed part, (i.e. focuser body) or mount handle. Slewing the scope by the diagonal could cause image shift when you release.
- 7) When changing an eyepiece, it is advisable to first lock one of the altitude tension screws tight before removing the eyepiece from the telescope. Once you have changed eyepieces, loosen that altitude tension screw to resume normal movement.

Parts Check List

- Tele-Pod Mount (TPM-3015)
- Tripod Bag
- Mount Handle
- Small-Parts Bag: (2) Studs for scope attachment, (2) Plastic Knurled Knobs, (4) Allen Keys: (1) 1/8", (1) 5/64", (1) 3mm, (1) 6mm, (3) spiked feet, & (1) double-sided wrench

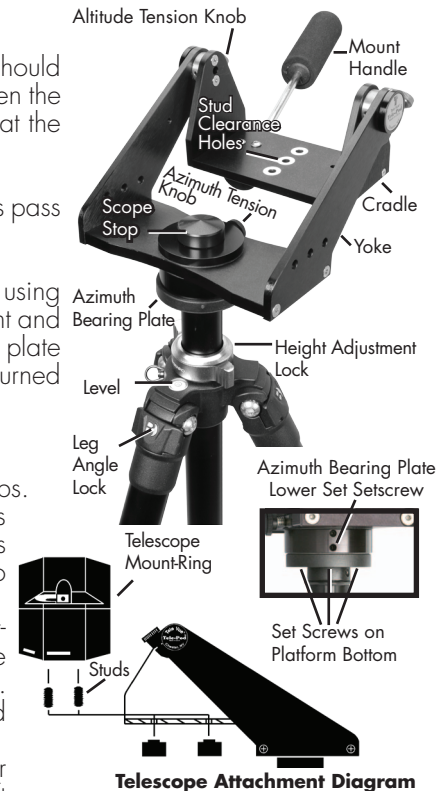
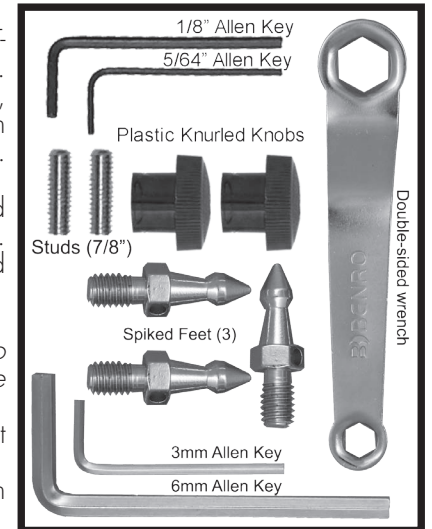

WARNING: Rotating the Tele-Pod head while the azimuth tension knob is tightened could cause the azimuth bearing to unscrew and separate.

(TPT-3017) TELE-POD TRIPOD INSTRUCTIONS

PARTS LIST

•Tele-Pod Tripod (TPT-3017) •Carry Bag with strap •Tools: Allen Keys: (1) 3mm & (1) 6mm, (1) Double-sided wrench •(3) Spiked feet.

INTRODUCTION & COMPONENTS

Thank you for purchasing the Tele-Pod Tripod. This lightweight, aluminum tripod consists of the tripod legs with **Bubble Level** and **Leg Angle Locks**, an extending and reversible center column with weight hook, and a center column **Platform** with a reversible 3/8"-16 or 1/4"-20 **Thread Adapter**. A carry bag with strap, tools, and spiked feet are included.

LEG & CENTER COLUMN CLAMP USAGE

A decal above the topmost **Leg Clamps** show the direction to turn these clamps to lock or unlock the legs. You only need to unlock the leg clamps a quarter turn to extend and contract the legs freely. **WARNING: Do not completely unscrew the Leg Clamps. Doing so may allow shims inside the hollow legs to fall out.**

Looking from above, the blue center column **Height Adjustment Lock** is turned a quarter turn counterclockwise from the locked position to loosen. Tighten clockwise until snug.

WARNING: Loosening the Height Adjustment Lock while the tripod is carrying a heavy camera or scope can cause a sudden center column drop that can injure your fingers or topple the tripod. When under load, support the center column with one hand while loosening it just enough to move with the other hand.

LEG ANGLE LOCKS

Normally the **Leg Angle Locks** are kept pushed in. This prevents the legs from spreading past a safe angle and collapsing. Pulling out the **Lock** allows a leg swing out to almost a 90° angle. **WARNING: It is recommended to adjust the legs in this way only if necessary and do so before mounting a camera or telescope to the tripod.**

LEG TIGHTENING

If a leg feels too loose or tight when swung open or closed, use the 6mm Allen Key to tighten or loosen the **Leg Tension Bolt** on either side of the leg hinge.

REVERSE MOUNTING THREADS

The tripod comes set to use the 3/8"-16 **Thread Adapter** in order to mount to our Tele-Pod head. It can be reversed to accept 1/4"-20 hardware. With the tripod level, use the big end of the double-sided wrench to loosen the retaining nut at the base of the **Thread Adapter**. You can then grasp the **Thread Adapter** and turn it counter-clockwise to remove. (**WARNING: Without Thread Adapter locked in place the Platform will be loose and can fall off if the tripod is tipped.**) With the **Thread Adapter** fully removed, spin the locking nut until it is about 1/2" away from the thread tip you want to use. Now thread the **Adapter** back into the tripod by turning it clockwise until the nut is nestled in the **Platform**. Note that the locking nut may spin out of position – so be prepared to spin it back before reaching the end of travel. Use the wide-end of the double-sided wrench to tighten the nut clockwise against the **Platform**.

SPIKED FEET

Depending on the terrain you might want to install the included foot spikes on the bottom of the tripod legs. To do so, first tighten the **Leg Clamps** so the legs don't turn. Unscrew the rubber tipped feet by hand. Screw in the spiked foot and then snug it with a slight twist using the large end of the double-sided wrench. Excessive tightening of the spike will cause rotation of the lower leg section.

TELE-POD HEAD INSTALLATION

- 1) Extend each tripod leg so that the mounting **Platform** is approximately level.
- 2) To install your camera head or telescope head on the 3/8"-16 stud, simply thread it on until it is tight.
- 3) Loosen the **Height Adjustment Lock** and raise the center column a few inches. Lock the center column.
- 4) Using the 3mm Allen Key, tighten the three **Set Screws** on the bottom of the tripod platform to lock your head.

USAGE

WARNING: If setting a up on a slope, ensure that the tripod legs are extended so that the head is approximately level with the horizon. Use the Bubble Level on the tripod for reference. Failure to do so could cause the telescope to tip over! This risk increases when using larger, longer scopes. Extend each tripod leg by loosening the **Leg Clamps** and tightening at the desired height. Make sure the bubble is approximately in the center of the level.

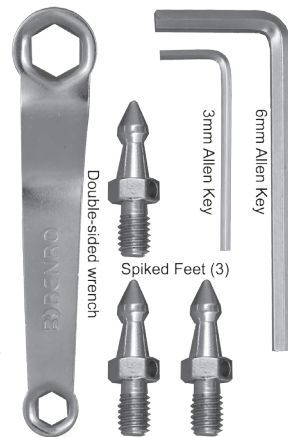

MOUNTS with ENCODERS SET-UP INSTRUCTIONS

Introduction

The addition of Digital Setting Circles or computers (DSC / Computer) to the mount head greatly enhances your fun and capability. For utmost convenience, we recommend the optional Eyepiece Caddy to hold your eyepieces and attach a mounting bracket or plate for your DSC / Computer. This sheet covers installing your DSC / Computer on our encoder equipped mount head with and without the optional Eyepiece Caddy. See Mount Instructions for setting up tripod, head, telescope attachment, and general use before continuing here.

Optional Components

The optional Eyepiece Caddy Set mounts to the Yoke arms of the head and provides a place to put 5 eyepieces. Holes on the left and right Caddy brackets can be used to mount a plate or bracket to support your DSC / Computer within arms reach.

Installation

Optional Eyepiece Caddy Set

For installation see instruction sheet that came with Eyepiece Caddy Set.

"Y"-Cable Harness

This cable contains one large RJ-45 "Ethernet" jack with cables that terminate in two RJ-11 "telephone" jacks. These smaller jacks are labeled "azimuth" and "altitude".

The azimuth jack should already be connected to the Azimuth encoder. Take the altitude jack and connect it to the Altitude encoder. Then put the large jack into your DSC / Computer.

DSC / Computer Wiring Connections

Once you're satisfied with your position choice below, use hook and loop or similar detachable fastener to attach the DSC / Computer. This will make it easier to relocate your device if there is need to.

If the DSC / Computer is used without a support plate or bracket, you must decide the best location for mounting your DSC / Computer so there is no danger of wires wrapping around the mount as it rotates. The outside of the yoke arm without encoder is a good location. Make sure the DSC / Computer is oriented to make it easy to plug and unplug the connections.

If DSC / Computer bracket is attached to the Caddy, there are two 5/32" clearance holes on each Caddy to use with screws or bolts for mounting a support plate you provide. Pick the left or right Caddy depending on which hand you want to use.

DSC / Computer Setup

- Mount-Type: Alt-Az or Dobsonian
- Encoder Steps / Resolution: 2160

Please follow the instructions in your DSC / Computer manual to set the above values for Tele Vue encoders and verify or change the encoder direction sense.

Please refer to the operating guide for specific instructions on use of your DSC / Computer.

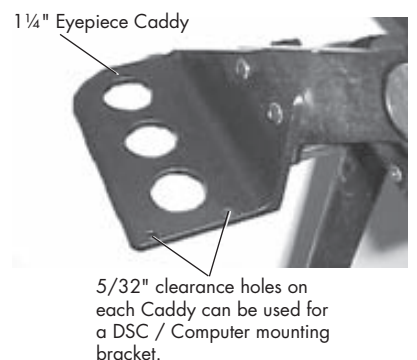
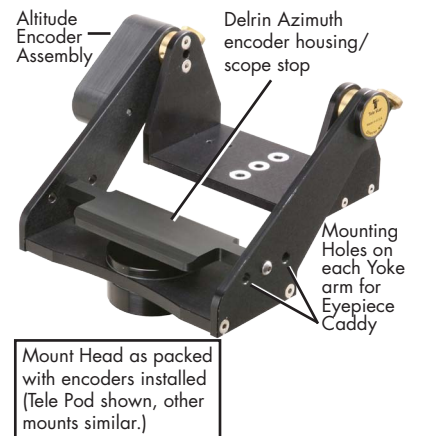

GREAT ACCESSORY: EYEPIECE CADDY SET

Part Numbers

Eyepiece Caddy Set (TEC-1018)

INTRODUCTION

This versatile accessory attaches to the yoke arms of your Tele Vue mount and places five eyepieces conveniently at your fingertips. The Caddy Set is precision machined aluminum, and powder-coated for lifetime durability. It's a *must have* item for Tele-Pod owners.

Available clearance holes at the ends of each Caddy can be used as mounting points for your DSC / Computer.

INSTALLATION

The most current yoke and cradle heads have the attachment holes already drilled into the arms. Attach each Caddy bracket by passing the screws through the clearance holes in the yoke arms and fixing the wing knob tight.

The angled edge will match the arms, so that when viewing from the telescope eyepiece position, the (3) 1 1/4" holes will be on the left side, while the (2) 2" holes with removable 1 1/4" plastic plugs will be to your right.

USE

You can place up to (5) 1 1/4" eyepieces in the Caddy Set, or by removing the plastic inserts, use (3) 1 1/4" and (2) 2" eyepieces. To remove the 1 1/4" inserts, push up from the bottom. To reinstall the 1 1/4" inserts, push them in from the top by running your thumbs around the outer lip. They will snap into place.

If you have dual barrel eyepieces you can use either 1 1/4" or 2" holes, but the outside lock screw in the 2" eyepiece barrel must be removed.

Of course, your Barlow or Powermate units, or 2" to 1 1/4" adapters can also be placed in the Caddy Set.

DSC / Computer Mounting

The ends of the Eyepiece Caddy make a good mounting location for your DSC / Computer. This conveniently locates the unit at your fingertips. There are two 5/32" clearance holes available on each Caddy to use for mounting a support plate you provide.

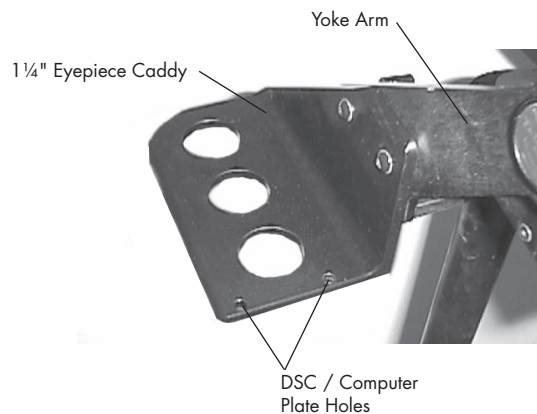
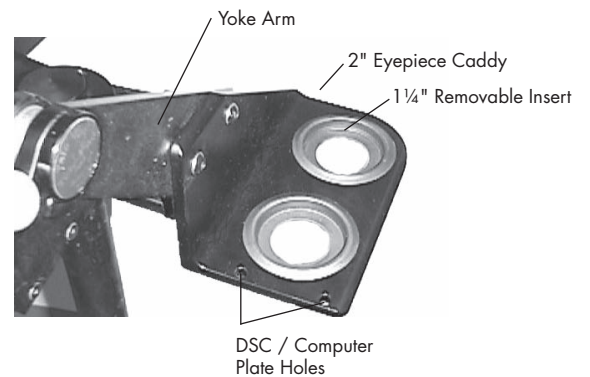
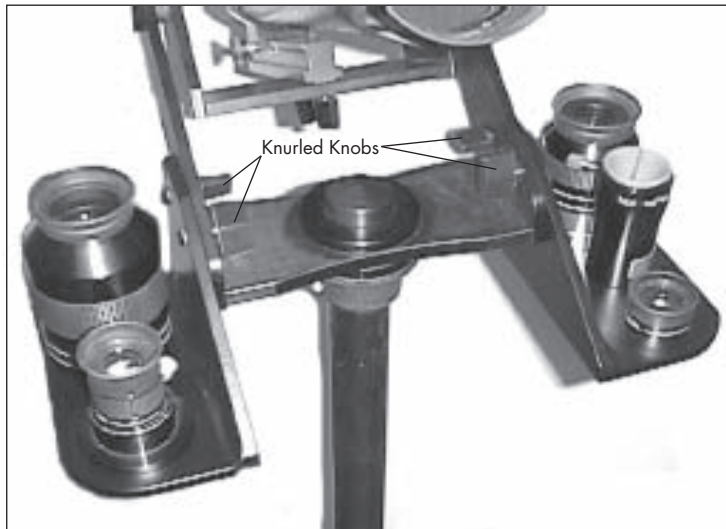

Typical DSC / Computer mounting location (not sold by Tele Vue)